



## Temperature sensor with ABS head **SG 100**

- Temperature sensor with a PT100 Class A stainless steel probe.
- Measuring range from 0 to +50°C, from -20 to +80°C, from -50 to +50°C, from 0 to +100°C. (According to model, see "Configuration").
- 0-10 V output, active sensor, power supply 24 Vac/Vdc (3-4 wires) or 4-20 mA output, passive loop, power supply 18 to 30 Vdc (2 wires).
- ABS IP 65 housing, with or without display.
- Quick and easy mounting ¼" turn system with wall-mount plate.
- LCC100 configuration software (optional).
- With or without stainless steel sliding connection, ½" cylindrical Gas.

### Part numbers

To order, just add the codes to complete the part number :

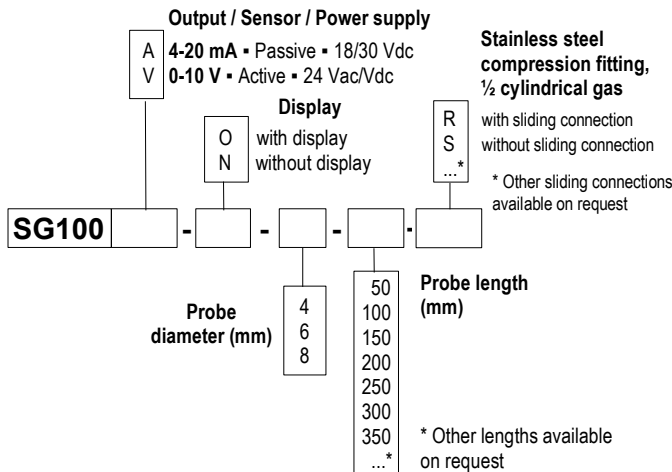

**Example : SG100 - V - O - 4 - 100 - R**

Model : PT100 Class A temperature sensor, with display.  
Stainless steel probe Ø 4, length 100 mm with stainless steel compression fitting ½" cylindrical gas on IP65 ABS housing. 0-10V active sensor with a 24 Vac/Vdc power supply.

### Housing dimensions (including wall-mount plate)

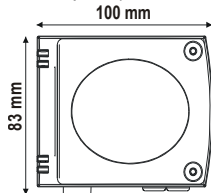

#### Without compression fitting

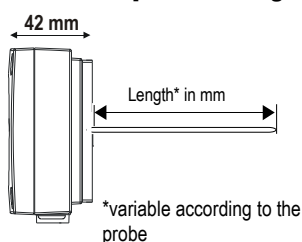

#### With compression fitting

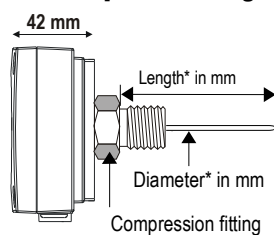

#### For thermowell using

Thread model : add 20 mm to probe length.  
Fixing screw model : add 10 mm to probe length.

### Transmitter features

Measuring range.....	see table ("configuration")
Units of measurement.....	°C, °F
Accuracy*.....	±0,5% of reading ±0,4°C (PT100 Class A)
Resolution.....	0,1°C
Type of sensor.....	PT 100 Class A as per DIN IEC751
Working temperature (probe).....	from -50°C to +100°C
Probe.....	316 L stainless steel, ¾ to 4/4 hard, no welding
Compression fitting.....	316 L stainless steel, ½"G male

\*all accuracies indicated in this technical datasheet were stated in laboratory conditions, and can be guaranteed for measurements carried out in the same conditions, or carried out with calibration compensation.

### Technical specifications

Output / Power supply.....	active sensor 0-10 V (power supply 24 Vac/Vdc ± 10%), 3-4 wires passive loop sensor 4-20 mA (power supply 18/30 Vdc), 2 wires maximum load : 500 Ohms (4-20 mA) minimum load : 1 K Ohms (0-10 V)
Consumption.....	2 VA (0-10V) or max. 22 mA (4-20mA)
Electro-magnetical compatibility.....	EN 61326
Electrical connection.....	screw terminal block for cables 1.5 mm <sup>2</sup> max
Communication to PC.....	Kimo RS 232 cable
Environment.....	air and neutral gases

WITH or WITHOUT display



### Housing features

Housing.....	ABS
Fire-proof classification.....	H-B as per UL94
Dimensions.....	see drawings beside
Protection.....	IP 65
Display.....	5- digits LCD. Dimensions 50 x 15 mm
Height of the digits.....	10 mm
Cable grip.....	for cables Ø 7mm max.
Weight.....	145g (with display) – 110g (without display)
Working temperature (housing).....	from -20°C to +50°C (with display) from -20°C to +80°C (without display)

## ■ Connection

For models  
SG 100 - V - O & SG 100 - V - N • Output 0-10 V – active sensor

Connection to PC  
LCC100 software

(d) DIP Switch  
(a) Output terminal block  
(b) Power supply terminal block  
(c) Cable tubing

**Power supply**

(b) Vdc.....direct voltage  
GND.....ground

**OR**

(b) Vac.....alternative voltage (phase)  
Vac.....alternative voltage (neutral)

**Output**

(a) GND.....ground  
Vdc T.....direct voltage (temperature)

(c) Cable grip : to insert the cable, it is required to slightly cut the rubber.

---

For models  
SG 100 - A - O & SG 100 - A - N  
• Output 4-20 mA – passive loop

(a) Vdc.....direct voltage  
IT.....direct current (temperature)

(a) Terminal block

## ■ Electrical connection - as per norm NFC15-100

This connection must be made by a qualified technician. To make the connection, the transmitter must not be energized.

For models  
SG 100 - V - O & SG 100 - V - N • Output 0-10 V – active loop

**4 wires**

Output terminal block: GND, Vdc T, Vdc

Power supply terminal block: Vdc, GND

Power supply: 24 Vdc

OR

Power supply: 24 Vac Class II

Regulator display or PLC / BMS Passive type

**3 wires**

To make a 3-wire connection, **before powering up the transmitter**, connect the ground to the output of the input ground. See drawing below.

Output terminal block: GND, Vdc T, Vdc

Power supply terminal block: Vdc, GND

Power supply: 24 Vdc

OR

Output terminal block: GND, Vdc T, Vdc

Power supply terminal block: Vdc, GND

Phase Neutral Power supply: 24 Vac

For models  
SG 100 - A - O & SG 100 - A - N • Output 4-20 mA – passive loop

**2 wires**

Power supply: 18-30 Vcc

Output terminal block: Vdc, Ir, GND, Vdc T

Regulator display ou PLC / BMS passive type

**OR**

Output terminal block: Vdc, Ir, GND, Vdc T

Regulator display or PLC / BMS active type

## ■ Configuration

You can configure all parameters of the transmitter : measuring ranges, units, output (according to model) either by DIP switch and/or via software (see below)

### ■ Configuration by **DIP switch**

To configure the transmitter, please unscrew the 2 screws from the housing, and then open it.



Whilst configuring the transmitter, **it must not be energized**. Make the required setting with the DIP switches (as shown on the drawing beside). When the transmitter is configured, you can power it up.

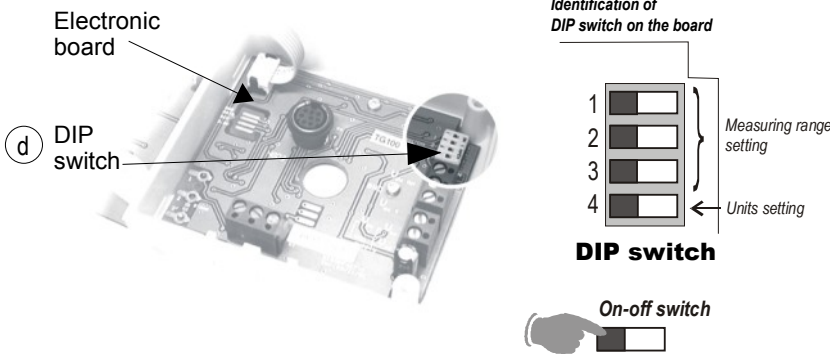









### ⚠ Caution !

**Please follow carefully the combinations shown alongside on the DIP switch.** If the combinations are wrong, the following message will appear on the display of the transmitter **“CONF ERROR”**. In that case, unplug the transmitter, set the DIP switches correctly, and then power up the transmitter.

















### • Units setting

To set measuring unit, set the on-off DIP switch, as shown alongside.

Configurations	°C	°F
Combinations	1 	1 
	2 	2 
	3 	3 
	4 	4 

### • Measuring range setting



To set the measuring range, set the on-off switches 1, 2 and 3 of the measuring range, as shown alongside.



Configurations	Measuring ranges			
	0 to 50 °C	-20 to 80 °C	-50 to 50 °C	0 to 100 °C
Combinations	1 	1 	1 	1 
	2 	2 	2 	2 
	3 	3 	3 	3 
	4 	4 	4 	4 

### ■ Initialization of the transmitter

When the transmitter is powered up, it initializes and displays the digits , and then its configuration including :  
**- The measuring range**    **- The analogue output.**

#### 1 – The measuring range.

The following message is displayed :  . This is the low value of the measuring range, and its digit value : **ex** : 

The following message is displayed :  . This is the high value of the measuring range and its digit value : **ex** : 

The arrow displayed (at the bottom or on the right of the screen) is relative to the unit of measurement : **ex** : from 0 to 100 °C.

#### 2 – The analogue output.

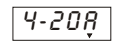
If the analogue output is in 4-20mA, then the following message will appear : 

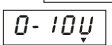
If the analogue output is 0-10 V, then the following message will appear : 

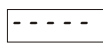
After the display of the configurations, the transmitter displays , which confirms that the initialization is finished and you can start the measurements.

## Configuration via software

(with optional LCC100 software)

### Easy, user-friendly configuration with the software !

You can configure your own intermediate ranges.

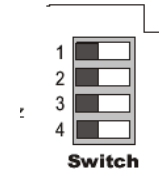

Example : for a transmitter with a range of -50 to +100°C, the minimum configurable range is 20°C. For example, you can configure your transmitter with a range from -20 to +80°C, or from +80 to +100°C...

• To access the configuration via software, first of all, set the DIP switch as shown below, then connect the cable to the transmitter (see alongside and refer to "Connection").

• Please refer to the user manual of the LCC 100 to make the configuration.



### Caution !

The configuration of the parameters can be done either with the **DIP switch**, or via **software** (you cannot combine both methods).

## Mounting

Installation : mount the ABS plate on the wall (this plate is supplied with the transmitter). Drilling :  $\varnothing$  6 mm (with the screws and plugs supplied with the transmitter). Insert the transmitter on the plate (see A on the drawing beside) and rotate its housing in clockwise direction until you hear a "click" which confirms that the transmitter is correctly installed.

For the model with duct mount, an additional hole  $\varnothing$ 14mm must be made before mounting the ABS plate.

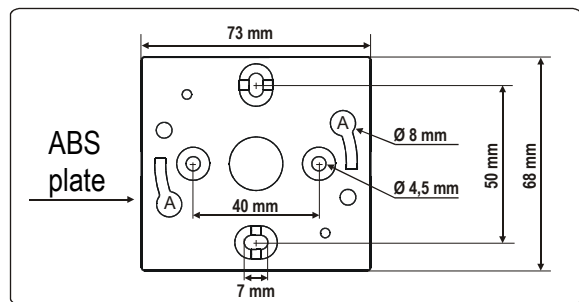

## Tolerance of the PT100 Class A.

Temp°C	Tolerances Class A	
	$\pm$ °C	$\pm$ Ohms
-50	0.25	0.1
0	0.15	0.06
100	0.35	0.13

## Maintenance

Clean the housing and probe only with cloth dampened with soapy water. Please avoid any of the following solvents at any concentration : petrol, petroleum, acetone, trichloroethylene, ammonia, acid, bicarbonate soap or bleach.

### Options

- Power supply class 2, input 230 Vac, output 24 Vac, **ref.KIAL-100A**
- Power supply class 2, input 230 Vac, output 24 Vdc, **ref.KIAL-100C**
- Configuration LCC 100 software with RS 232 cable



### Accessories (See Datasheet)

- Stainless steel compression fitting
- Stainless steel mounting brackets
- Thermowells

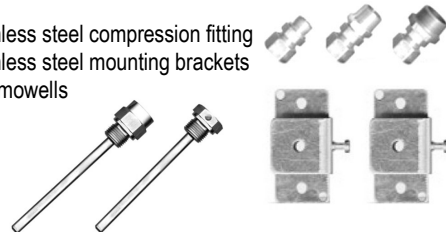

### Händlerkontakt: